

Gas Meter Specifications		
Product name	STK2.5	
Maximum flow rate	2.5m ³ /h	
Starting flow rate	1L/h	
Chamber volume	0.7L/rev.	
Maximum operating pressure	3.5kPa	
Maximum pressure	10kPa	
Maximum index	9,999m ³	
Dimension	Height	230mm
	Width	167mm
	Depth	135mm
	Span (inlet and outlet)	130mm
Connection threads	W36.3 – 11.5	
Connection pipe	3/4B(20A)	
Weight	1.95 kg	

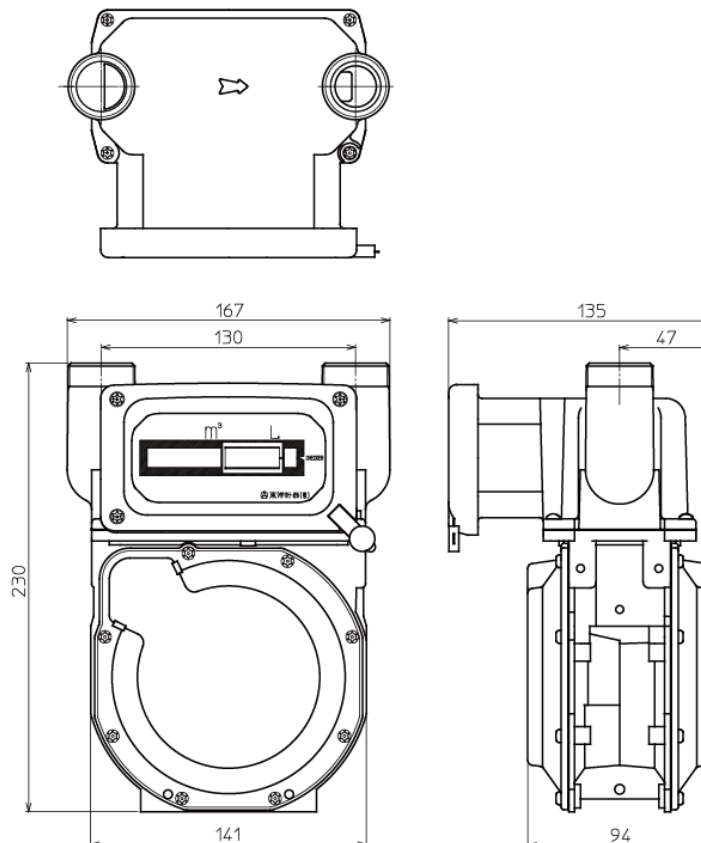

[Unit mm]